

NEUTRON FILTER BEAMS AT THE KYIV RESEARCH REACTOR

O. Gritzay, V. Koloty, V. Libman, O. Kalchenko, N. Klimova

Institute for Nuclear Research, National Academy of Sciences of Ukraine, Kyiv, Ukraine

This is a short review of the neutron filtered beam technique developed in Neutron Physics Department (NPD) of the Institute for Nuclear Research at Kyiv Research Reactor (KRR) by now. Ways of searching of new neutron filters and improving of known neutron filters are described. Through expensiveness of high enriched isotopes, the natural elements or enriched isotopes available in the NPD were considered as components of the new or improved filters. Short information about characteristics of the existing filters is presented.

1. Basic principles of neutron filters development

The main idea of neutron filter development is the use of large quantities of matter which nuclei have the deep interference minima in their total neutron cross sections. By transmitting reactor neutrons through thick layer of such material, one can obtain the quasi-mono-energetic neutron lines instead of white reactor spectrum. To get only one quasi-mono-energetic neutron line it is possible to use the two ways:

1) to take so thick layer of this material that only neutrons, corresponding to the most deep interference minimum, would be able to pass through it;

2) to use additional materials, for which resonance maxima in their total neutron cross sections coincide with interference minima for filter material, with the exception of the most deep interference minimum energy.

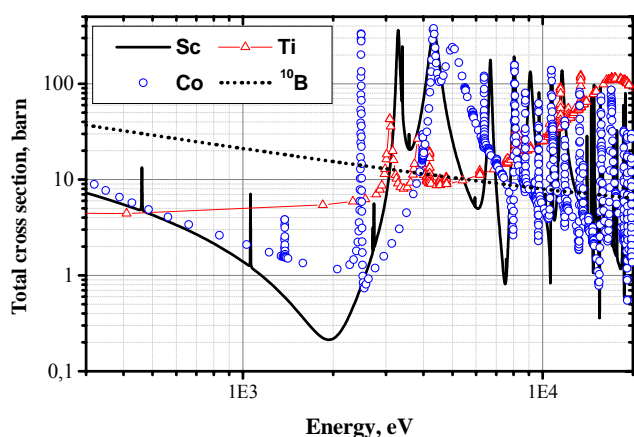

Fig. 1. Total neutron cross sections for Sc, Ti, Co, and ^{10}B in the energy range from 0.3 to 20 keV (JENDL-3.3 library).

total neutron cross sections is unreal (Fig. 1, in which the total neutron cross sections for all materials of the 2 keV composite filter are presented). The selection by means of experimental investigations can demand a lot of reactor time. Therefore the best way to optimize a filter composition is execution of preliminary modeling calculations, with subsequent test of this calculated filter by experiment. Methods, realized for this aim in the NPD, will be described below.

Now let formulate the basic demands to neutron filters:

1. The purity of the main energy line in neutron spectrum has to be as much close to 100 % as possible.
2. Neutron intensity has to be the most possible value, sufficient to obtain the necessary accuracy in experiment.
3. Construction and composition have to provide the minimal possible gamma-background.
4. In necessary case construction and composition have to allow to increase or to reduce the width of base line without essential worsening of filter quality.
5. The amount of enriched isotopes in filter components has to be minimum necessary.
6. Filter components have to provide the energy range of filtered neutrons up to 1 MeV and more.

2. Neutron filters at the Kyiv research reactor

The KRR is a tank-type reactor with beryllium reflector and light water both as moderator and coolant. The core is an assembly of fuel rods, which are 36 % enriched with uranium-235. The nominal thermal power is 10 MW. Neutron flux in the core is about 10^{14} n/cm²s. The KRR has ten horizontal tubes, which are used for nuclear physics investigations, solid state and material structure study and applied works. Now three of these ten horizontal tubes are employed in experimental investigations with using of the neutron filtered beam technique. The typical construction of forming system of filtered neutron beam at the KRR is presented in Fig. 2.

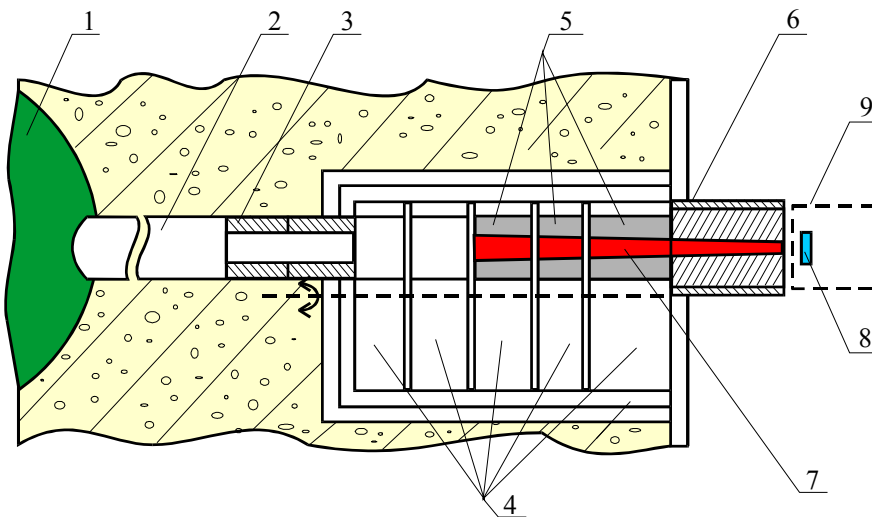

Fig. 2. Construction of forming system of filtered neutron beam on the KRR to obtain the quasi-mono-energetic neutron line. 1 – beryllium reflector; 2 – horizontal channel tube; 3 – preliminary collimator; 4 – beam shutter disks; 5 – filter-collimator assemblies; 6 – outside collimator; 7 – filter components; 8 – sample for activation; 9 – device for samples removing.

The forming system of filtered neutron beam includes the elements of beam collimation and neutron filtration on the way from reactor core to detector. The preliminary forming of necessary beam geometry is realized with two iron and boron carbide collimators, installed behind the shutter at the 1.5 m distance from a channel beginning. General length of the collimators are 600 mm (390 mm - iron, 210 mm - boron carbide). Further beam forming takes place in the first three discs of shutter and in outer collimator. By turns lead, textolite and mixture of paraffin with H_3BO_3 are used as material for these collimators. The collimation system provides beam narrowing to 12 mm/m that corresponds to beam diameter at the sample in 10 mm. The elements of neutron filtration system take place in the first three discs of shutter and in outer collimator.

The wide set of natural elements and enriched isotopes are used as components for neutron filters in NPD at KRR:

- Natural elements: Si, Al, V, Sc, S, Mn, Fe, Ti, Mg, Co, Ce, Cr, Rh, Cu, B, Cd, LiF.
- Enriched isotopes: ^{52}Cr (99.3 %), ^{54}Fe (99.92 %), ^{56}Fe (99.5 %), ^{57}Fe (99.1 %), ^{58}Ni (99.3 %), ^{60}Ni (92.8 % – 99.8 %), ^{62}Ni (98.04 %), ^{80}Se (99.2 %), ^{10}B (85 %), 7Li (90 %).

Availability of such wide set of materials, especially enriched isotopes, allowed to create in NPD the unique set of neutron filters, providing more than ten neutron lines in the energy range from thermal energy to several hundred kilo-electron-volts, intensity of such lines may reach $10^6 - 10^8$ n/cm²s [2], and this is much more than any other method (time of flight or others) can ensure. The wide set of filter materials also allows us to modify filter parameters (purity, intensity, width, etc.) subject to the given research task. Through expensiveness of high enriched isotopes, the natural elements or enriched isotopes available in NPD are usually considered as components of new or improved filters.

The filter component optimization procedure intended for getting the most possible intensity of the main energy line at the most possible low intensity of the parasitic energy lines in filtered neutron spectrum includes the following three main steps:

- 1-th step: modeling calculation of neutron filtered spectra;
- 2-nd step: creation of filter with calculated amount of the chosen components;
- 3-rd step: experimental testing of the created filter.

If it is necessary the sequence of these steps is repeated. If desired quality of filter is attained, its characteristics are determined.

2.1. Modelling calculation of neutron filtered spectra

For modelling calculation of neutron spectra formed by filters, there were developed the special computer code using FORTRAN language. This code FILTER allows putting into calculation practically any material and isotope combination that are used to get the filtered neutron spectrum with necessary energy.

This code FILTER (version 5) allows obtaining the two energy dependent values which image the filtered neutron spectrum:

1. Neutron transmission $T(E)$ multiplied by incident reactor neutron spectrum $\Phi(E)$:

$$F1(E) = T(E) * \Phi(E) \equiv \exp[-\sum n_i * \sigma_i(E)] * \Phi(E), \quad (1)$$

where n_i – nuclear thickness of the i-th filter component; $\sigma_i(E)$ – total neutron cross section of the i-th nuclide.

2. Neutron transmission $T(E)$ multiplied by incident reactor neutron spectrum $\Phi(E)$ and multiplied by an energy dependent cross section of the reaction, which used for neutron detection $\sigma_{react}(E)$, i.e. it allows to take into account an efficiency of the used neutron detector:

$$F2(E) = T(E) * \Phi(E) * \sigma_{react}(E). \quad (2)$$

The incident reactor neutron spectrum $\Phi(E)$ is taken as function composed of 3 parts: Maxwellian, $1/E$ – dependence and fission spectrum. This spectrum was normalized to unit: $\int \Phi(E)dE = 1$ in the limits from 10^{-5} eV to 20 MeV.

The total neutron cross sections for nuclides $\sigma_i(E)$ were obtained from ENDF libraries in the energy range from 10^{-5} to 20 MeV in point-wise form at the temperature 300K using the PREPRO2002 [3] and NJOY99 [4] codes. JENDL-3.3, ENDF/B-6 libraries were taken as the basis for forming this special library. Today it consists of 65 files; each of them includes the total neutron cross section for one nuclide. That structure of the cross section library allows to realize in the FILTER code a selection as filter component any nuclide by name of its file, combination them in any sequence, and, if it is necessary to add new files with needed cross sections.

The opportunity of using these simple expressions for determination of a neutron spectrum shape after filter is due to a strict collimation of neutron filtration system, otherwise it would be necessary to calculate a neutron transport from core to sample place taking into account all processes (scattering, absorption, etc.). Correctness of this statement was tested by calculation of a neutron spectrum shape after the 24 keV filter using MCNP4c code [5]. The MCNP4c results were similar to those obtained by means our code FILTER.

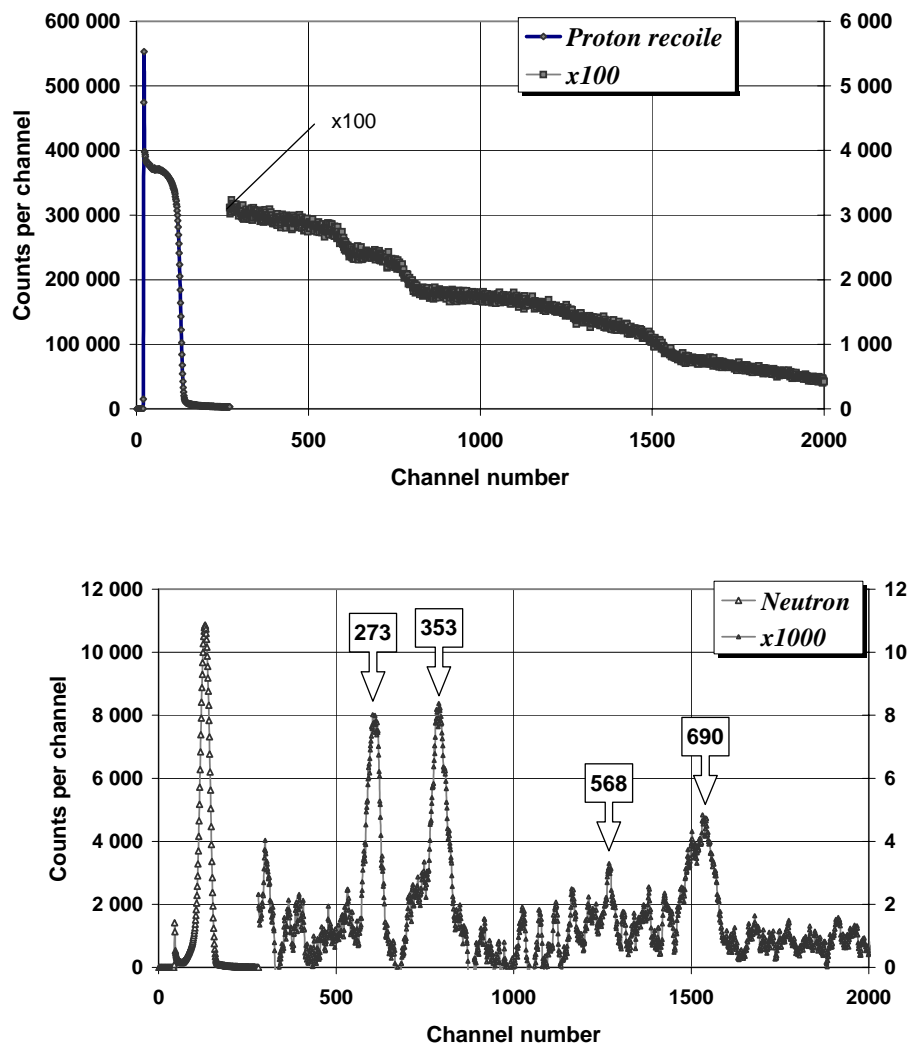

Fig. 3. Instrumental spectrum from proton recoil counter after neutron filter with energy 59 keV (top picture), and the shape of neutron filtered beam spectrum obtained by differentiation of previous curve (lower picture).

2.2. Creation of filter with calculated amount of the chosen components

As a rule, when we create a new filter (or improve an existing one) with energy different from thermal, the first filter component, having location on the beginning of the third beam shutter disk (the most close to core), is boron-10, to avoid excessive activation of the rest filter components. Also in the first three shutter disks the main components of filter are inserted. The filter components, which are planned to alter, are placed, if it is possible, in outside collimator. To lighten and to quicken the procedure of filter changing, special containers for filter were made. These containers are tubes from stainless steel, length of them are equal to length of beam shutter disks. Collimation materials (ordinarily paraffin with H_3BO_3 and lead, taking turns) and filter components are inserted in these tubes.

2.3. Experimental testing of the created filter

To demonstrate procedure of experimental testing of the created filter let us consider the filter, main components of which are S, ^{58}Ni , V, ^{10}B , and Al. Results of calculation with the code FILTER show that if we take ^{10}B - 0.281 g/cm², ^{58}Ni - 83.15 g/cm², V - 17.4 g/cm², S - 122.55 g/cm², Al - 5.4 g/cm², we can obtain a neutron filter with energy 59 keV and the purity of this filter will be better than 99 %, other additions to the main spectra will be negligible – each of lines is less than 0.2 %. This filter was arranged and a neutron spectrum after them was measured by means proton recoil counter. The experimental results are shown in Fig. 3. On the lower part of this Figure the shape of neutron filtered beam spectrum obtained by differentiation of previous curve is presented. As it can be seen, contribution of the parasitic higher energy lines is negligible.

2.4. Filters used for fundamental and applied investigations in the NPD

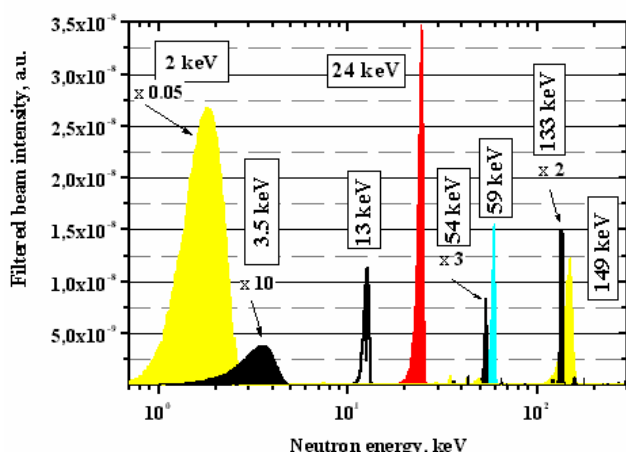

Fig. 4. Neutron filters used in the NPD for fundamental investigation.

quasi-monoenergetic neutron line, energy width of which may amount to several tens of kiloelectron-volts. For some tasks the large width of the neutron line is an advantage, but a set of tasks demands narrowing and/or splitting of broad neutron line into more narrow energy ranges. To solve this problem we propose to use "inverse" filters. As a matter of fact, "inverse" filter is a system consisting of the base filter, which forms neutron beam, and of the correcting sample, which is installed in the beam after this base filter.

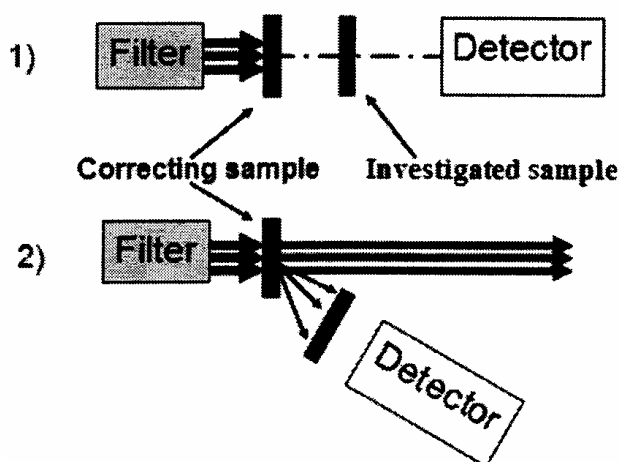

Fig. 5. Scheme of measurements with "inverse" filter.

As a result of this activity characteristics of the whole series of neutron filters were improved and today these filters are used for fundamental investigations, carried out in the NPD. Their energies and comparative intensity are shown in Fig. 4. Energy region, which they cover, is from thermal energy (this filter is not presented in Figure) to 149 keV.

New filter 7.5 keV was developed; main component of it is copper. Another filter is developing now in the NPD – the 275 keV filter. Main component of this filter is manganese. These filters are not presented in Fig. 4.

2.5. New direction in filter development in the NPD

So, using the interference filter it is possible to extract from reactor spectrum one rather intensive quasi-monoenergetic neutron line, energy width of which may amount to several tens of kiloelectron-volts. For some tasks the large width of the neutron line is an advantage, but a set of tasks demands narrowing and/or splitting of broad neutron line into more narrow energy ranges. To solve this problem we propose to use "inverse" filters. As a matter of fact, "inverse" filter is a system consisting of the base filter, which forms neutron beam, and of the correcting sample, which is installed in the beam after this base filter.

The correcting sample is intended for change the energy of the base filter. The change of the filter energy may be realized owing to various processes:

1. Through reduction of neutron energy in interaction between neutron and nuclei (see 1) in Fig. 5);
2. Through dependence of energy of scattered neutrons from angle of deflection (see 2) in Fig.5). Numerical simulation of change of the filter energy through both above-mentioned processes for one of existing base filter was performed and possibility of use of the existing experimental equipment for realization of the "inverse" filter technique was analyzed. This activity will be continued in the future.

Conclusion

The neutron energy range which can be covered by means of neutron filters is very interesting for advance in understanding the mechanism of neutron interactions with nuclei and for development of nuclear models, and it is very important for engineering calculations, but through absence of high intensity neutron sources in this energy region an accuracy of the available experimental data for a majority of nuclides is very low, for some of them the experimental data in this energy region is absent at all. High intensity of neutron beams and experimental methods developed in the NPD, made it possible to carry out the measurements with high accuracy.

REFERENCES

1. *Simpson O.D., Miller L.G.* A technique to measure neutron cross sections in the low keV energy region // Nucl. Instr. Meth. - 1968. - Vol. 61, No. 3.
2. *Gritzay O.O., Koloty V.V., Kaltchenko O.I.*, Neutron filters at Kyiv Research reactor. - Kyiv, 2001. - (Prepr. / KINR; KINR-01-6).
3. *Cullen D.E.* The 1992 ENDF Pre-processing Codes, IAEA-NDS-39, Rev. 7, Feb., 1992.
4. *MacFarlane R.E., Muir D.W.* The NJOY Nuclear Data Processing System, Version 91, LA-12740-M, October, 1994.
5. *Briesmeister, J.F.* (Ed.), 2000. *MCNP - A General Monte Carlo N-particle Transport Code*, Version 4C, LA-13709 M.